



# Standard Test Methods for Rubber Property—Heat Generation and Flexing Fatigue in Compression<sup>1</sup>

This standard is issued under the fixed designation D623; the number immediately following the designation indicates the year of original adoption or, in the case of revision, the year of last revision. A number in parentheses indicates the year of last reapproval. A superscript epsilon ( $\epsilon$ ) indicates an editorial change since the last revision or reapproval.

## 1. Scope

1.1 These test methods may be used to compare the fatigue characteristics and rate of heat generation of different rubber vulcanizates when they are subjected to dynamic compressive strains.

1.2 The values stated in SI units are to be regarded as the standard. The values given in parentheses are for information only.

1.3 *This standard does not purport to address all of the safety concerns, if any, associated with its use. It is the responsibility of the user of this standard to establish appropriate safety and health practices and determine the applicability of regulatory limitations prior to use.*

## 2. Referenced Documents

### 2.1 ASTM Standards:<sup>2</sup>

[D395 Test Methods for Rubber Property—Compression Set](#)  
[D1349 Practice for Rubber—Standard Temperatures for Testing](#)

[D3182 Practice for Rubber—Materials, Equipment, and Procedures for Mixing Standard Compounds and Preparing Standard Vulcanized Sheets](#)

[D4483 Practice for Evaluating Precision for Test Method Standards in the Rubber and Carbon Black Manufacturing Industries](#)

### 2.2 ASTM Adjuncts:

[Goodrich Flexometer Anvil Drawings](#)<sup>3</sup>

## 3. Summary of Test Method

3.1 The test consists of subjecting a specimen of rubber of definite size and shape to rapidly oscillating compressive

<sup>1</sup> These test methods are under the jurisdiction of ASTM Committee D11 on Rubber and are the direct responsibility of Subcommittee D11.15 on Degradation Tests.

Current edition approved May 1, 2014. Published May 2014. Originally approved in 1941. Last previous edition approved in 2007 as D623 – 07. DOI: 10.1520/D0623-07R14.

<sup>2</sup> For referenced ASTM standards, visit the ASTM website, [www.astm.org](http://www.astm.org), or contact ASTM Customer Service at [service@astm.org](mailto:service@astm.org). For *Annual Book of ASTM Standards* volume information, refer to the standard's Document Summary page on the ASTM website.

<sup>3</sup> Available from ASTM International Headquarters. Order Adjunct No. [ADJD0623](#). Original adjunct produced in 1939.

stresses under controlled conditions. Although heat is generated by the imposed oscillating stress, the more convenient parameter, the temperature rise, is measured. The measured temperature rise is one of two types: (1) to an equilibrium temperature or (2) the rise in a fixed time period. Additional measured performance properties are the degree of permanent set or other specimen dimensional changes, or both, and for certain test conditions, the time required for a fatigue failure by internal rupture or blow out.

3.2 Two test methods are covered, using the following different types of apparatus:

3.2.1 *Test Method A*—Goodrich Flexometer.

3.2.2 *Test Method B*—Firestone Flexometer.

## 4. Significance and Use

4.1 Because of wide variations in service conditions, no correlation between these accelerated tests and service performance is given or implied. However, the test methods yield data that can be used to estimate relative service quality of different compounds. They are often applicable to research and development studies.

## 5. Preparation of Sample

5.1 The sample may consist of any vulcanized rubber compound except those generally classed as hard rubber, provided it is of sufficient size to permit preparation of the test specimen required for the test method to be employed. The sample may be prepared from a compound mixed experimentally in the laboratory or taken from process during manufacture, or it may be cut from a finished article of commerce.

5.2 If prepared in the laboratory, the procedure should preferably be essentially as specified in Practice [D3182](#), except that when vulcanization is required, the sample should preferably be molded in block form of sufficient size to permit cutting of the required test specimens rather than in the form of the standard test slab.

5.2.1 The direct molding of the specimen for Test Method A is allowed (see [9.4](#)) but may not yield results identical to specimens cut from a molded block. Care must be taken in preparation on the raw stock for direct molding of specimens.

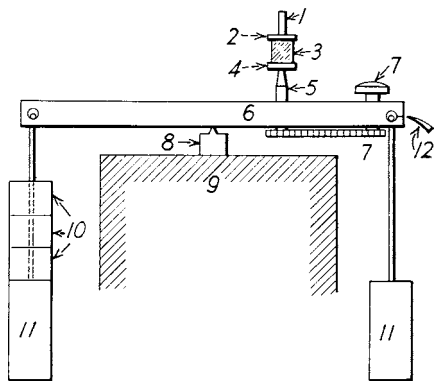

- 1—Connection to eccentric which drives top anvil.
- 2—Top anvil.
- 3—Test specimen.
- 4—Lower anvil.
- 5—Support for lower anvil.
- 6—Lever through which load is applied.
- 7—Calibrated micrometer device.
- 8—Bearing assembly or knife edge.
- 9—Supporting base.
- 10—Test load.
- 11—Inertia mass of 24 kg (53 lb).
- 12—Pointer and reference mark for leveling of lever.

FIG. 1 Goodrich Flexometer

5.3 Samples from commercial articles shall consist of a piece slightly larger than the required test specimen and shall subsequently be cut or buffed to size.

5.4 Comparison of results shall be made only between specimens of identical size and shape.

#### TEST METHOD A—GOODRICH FLEXOMETER<sup>4</sup>

### 6. Nature of Test

6.1 In this test method, which uses the Goodrich Flexometer, a definite compressive load is applied to a test specimen through a lever system having high inertia, while imposing on the specimen an additional high-frequency cyclic compression of definite amplitude. The increase in temperature at the base of the test specimen is measured with a thermocouple to provide a relative indication of the heat generated in flexing the specimen. Specimens may be tested under a constant applied load, or a constant initial compression. The change in height of the test specimen can be measured continuously during flexure. By comparing this change in height with the observed permanent set after test, the degree of stiffening (or softening) of the test specimen may be estimated. Anisotropic specimens may be tested in different directions producing measurable differences in temperature rise due to the anisotropy.

### 7. Apparatus

7.1 The essential parts of the apparatus are shown in Fig. 1. The test specimen is placed between anvils faced with inserts of a black NEMA Grade XX Paper-Phenolic, for heat-

<sup>4</sup> Lessig, E. T., *Industrial and Engineering Chemistry*, IENAA, Analytical Edition, Vol 9, 1937, pp 582-588.

insulation purposes. The top anvil or hammer is connected to an adjustable eccentric usually driven at  $30 \pm 0.2$  Hz (1800 rpm). The static load is applied by means of a lever having a fulcrum point consisting of a low friction bearing cartridge block or resting on a knife edge. The moment of inertia of the lever system is increased, and its natural frequency reduced, by suspending masses of approximately 24 kg (53 lb) at each end of the lever system. The lower anvil may be raised or lowered relative to the lever by means of a calibrated micrometer device. This device permits the lever system to be maintained in a horizontal position during the test as determined by a pointer and a reference mark on the end of the bar or a gear motor mounted to the end of the lever system to automatically drive the micrometer device based on sensors indicating the level position of the system. The increase in temperature at the base of the specimen is determined by means of a thermocouple placed at the center of the bottom anvil.

7.2 The machine may be equipped with a well-insulated, temperature-controlled oven to permit testing at elevated temperatures.

### 8. Adjustment

8.1 Locate the machine on a firm foundation. Adjust the leveling screws in the base to bring the machine into a level position in all directions at a point just to the rear of the fulcrum of the loading lever. With the loading lever locked in place with the pin, place a level on the lever bar and verify the level setting.

8.2 Adjust the eccentric to give a stroke of  $4.45 \pm 0.03$  mm ( $0.175 \pm 0.001$  in.) (Note 1). This is best accomplished by means of a dial micrometer resting on either the cross bar of the upper anvil or by means of adapters attached to the loading arm of the eccentric.

NOTE 1—The 4.45-mm (0.175-in.) stroke is selected as the standard for calibration purposes. When strokes other than 4.45 mm (0.175 in.) are to be used, the displacement of the lower anvil should be maintained within the tolerance specified for its height above the loading lever. The tolerance for all stroke settings shall be  $\pm 0.03$  mm ( $\pm 0.001$  in.).

8.3 Raise the top anvil as far as the eccentric will permit by its rotation. Place a calibrating block (Note 2)  $25.40 \pm 0.01$  mm ( $1.000 \pm 0.0005$  in.) in height on the lower anvil. Raise the anvil by means of the micrometer until the bottom side of the metal cup holding the thermocouple is  $67 \pm 3$  mm ( $2.625 \pm 0.125$  in.) above the top of the loading lever. The loading lever is to be in the locked position. Adjust the cross bar of the upper anvil, maintaining a parallel setting with the lower anvil and a firm contact with the calibrating block. The micrometer should now be set at zero. This may require disengagement of the gear train nearest the vernier scale of the micrometer. Remove the calibrating block and recheck the stroke for a 4.45-mm (0.175-in.) setting. Set the pointer on the mark on the end of the lever bar to mark the level position. If equipped with a computer system, follow the calibration procedure provided in the software.

NOTE 2—A suitable block may be made from brass having a diameter of 17.8 mm (0.7 in.). The end to be placed on the lower anvil should be counterbored for clearance of the thermocouple disk.

**TABLE 1 Recommended Load on Specimen**

NOTE 1—For calculation of masses, the long arm is 288.3 mm (11.35 in.) and the shorter arm 127.0 mm (5.0 in.).

Load on Beam		Load on Specimen		Unit Load on Specimen	
N	lbf	N	lbf	kPa	psi
70.5 ± 0.2	15.86 ± 0.03	160	36	644	93.54
108.0 ± 0.2	24.23 ± 0.03	245	55	990	142.91
216.0 ± 0.2	48.46 ± 0.03	489	110	1970	285.83

8.4 During the initial setup of the Flexometer, remove the locking pin from the loading lever and gently oscillate the lever system to determine the point of rest. If the bar does not come to rest in approximately the level position, slowly return it to its level position and release. If the movement from the level position is observed, add or remove a slight amount of weight to the required inertia weight to obtain a balance.

8.5 The rate of cyclic compression, usually  $30 \pm 0.2$  Hz ( $1800 \pm 10$  rpm) is maintained by means of the adjustable shive or shives for the V-belt drive. Many systems use an electronically controlled direct drive motor.

8.6 A Type J (IC) thermocouple using 0.40 mm (0.0159 in.) wire is centered in the face of the lower anvil. The black NEMA Grade XX Paper-Phenolic face is backed up with a hard rubber disk. The thermocouple may be connected to a recording device. A minimum of 100 mm (4 in.) of wire shall be retained in the oven when used at elevated temperatures.

8.7 A suitable oven for measurements at elevated temperatures may be purchased with the machine or constructed. The inside dimensions should be approximately 100 mm (4 in.) in width, 130 mm (5 in.) in depth, and 230 mm (9 in.) high. The top of the floor of the oven shall be  $25.4 \pm 2.5$  mm ( $1.0 \pm 0.1$  in.) above the loading lever.

8.8 The air circulation is to be maintained by a squirrel-cage type blower 75 mm (3 in.) in diameter. The air intake should have a diameter of approximately 59 mm (2.313 in.). The scroll opening for the air discharge shall be 38 by 44 mm (1.5 by 1.75 in.). A motor capable of maintaining a constant rpm under load between 25.8 and 28.3 Hz (1550 and 1700 rpm) shall be used for the blower. A platform shall be provided in the base of the oven on which the specimens may be placed for conditioning. Such a platform can suitably be obtained from 6-mm (0.25-in.) wire screen netting supported at least 9 mm (0.375 in.) above the floor of the oven.

8.9 A thermocouple of a matching type as that used in the lower anvil shall be used for measuring the ambient air temperature. It shall be located approximately 6 to 9 mm (0.25 to 0.375 in.) to the rear of the upper and lower anvils and slightly right of center. The sensing point should be at a point about midway between the anvils. A minimum 100 mm (4 in.) of wire should be retained within the oven.

8.10 A thermostatic control shall be capable of maintaining an ambient air within  $\pm 1.1^\circ\text{C}$  ( $2^\circ\text{F}$ ) of the set point.

## 9. Test Specimen

9.1 The test specimen as prepared from vulcanized rubber shall be cylindrical in shape, having a diameter of  $17.8 \pm 0.1$  mm ( $0.700 \pm 0.005$  in.) and a height of  $25 \pm 0.15$  mm ( $1.000 \pm 0.010$  in.).

9.2 The standard test specimen shall be cut from a laboratory slab, prepared in accordance with Practice D3182. The cured thickness shall be such that buffing is not required. See 5.2. A cured block approximately 76.2 by 50.8 by 25.4 mm (3 by 2 by 1 in.) has been found satisfactory.

9.3 The circular die used for cutting the specimen shall have an inside diameter of  $17.78 \pm 0.03$  mm ( $0.700 \pm 0.001$  in.). In cutting the specimen the die shall be suitably rotated in a drill press or similar device and lubricated by means of a soap solution. A minimum distance of 13 mm ( $\frac{1}{2}$  in.) shall be maintained between the cutting edge of the die and the edge of the slab. The cutting pressure shall be as light as possible to minimize cupping or taper in the diameter of the specimen.

9.4 An optional method of preparing the test specimen may be the direct molding of the cylinder.

NOTE 3—It should be recognized that an equal time and temperature if used for both the slab and molded specimen will not produce an equivalent state of cure in the two types of specimen. A “tighter” cure will be obtained in the molded specimen. Adjustments, preferably in the time of cure, must be taken into consideration if comparisons between the two types of specimen are to be considered valid.<sup>5</sup>

NOTE 4—It is suggested, for purposes of uniformity and closer tolerances in the molded specimen, that the dimensions of the mold be specified and shrinkage compensated for. A plate cavity  $25.78 \pm 0.05$  mm ( $1.015 \pm 0.002$  in.) in thickness and  $18.00 \pm 0.05$  mm ( $0.709 \pm 0.002$  in.) in diameter, with overflow cavities both top and bottom when combined with two end plates will provide one type of a suitable mold.

9.5 Samples from a manufactured article shall consist of a piece slightly larger than the required test specimen and shall subsequently be cut or buffed to size.

## 10. Recommended Test Conditions

10.1 Recommended load on the specimen is given in Table 1.

10.2 The stroke may be varied to provide a satisfactory test condition in respect to the load. The recommended strokes are 4.45 mm (0.175 in.), 5.71 mm (0.225 in.), and 6.35 mm (0.250 in.).

10.3 Under certain conditions, the machine may be operated at room temperature. Precautions must be taken, however, to return the base thermocouple to equilibrium and to maintain a uniform room temperature throughout the duration of the complete test. The oven shall be removed when testing at room temperature.

10.4 Tests conducted at  $50^\circ\text{C}$  ( $122^\circ\text{F}$ ) and  $100^\circ\text{C}$  ( $212^\circ\text{F}$ ) are recommended.

<sup>5</sup> Conant, F. S., Svetlik, J. F., Juve, A. E., “Equivalent Cures in Specimens of Various Shapes” *Rubber World*, RUBWA, March, 1958; *Rubber Age*, RUAGA, March, 1958; *Rubber Chemistry and Technology*, RCTEA, July-Sept. 1958.